

Absorbed Glass Mat VRLA Industrial Battery Block

Discover® Clean & Green™ Series EV Traction Dry Cell Industrial Batteries provide superior high integrity and reliability for environmentally sensitive areas, commercial, industrial and private applications. The maintenance-free, valve regulated lead acid (VRLA) construction makes Discover® EV Traction Batteries the definitive choice for Mobility and Home Medical Equipment (HME); Broadband and Cable TV (CATV); Uninterruptible Power Supplies (UPS); Telecommunication; Photovoltaic, Solar and Renewable Energy Storage; Electronic and Security; Marine and RV; Golf and Electric Vehicle; Aerial Lifts and Fork Lifts; Floor Machines and Robotics.

Features & Benefits

EV Traction Dry Cell

- Completely sealed valve regulated construction.
- Flame arresting pressure regulated safety sealing valves for safety, operating pressure management and protection against atmospheric contamination (excess oxygen being absorbed by negative plates).
- Computer-aided 99.994% pure heavy-duty lead calcium grid designs.
- Tank formed plates guarantees evenly formed and capacity matched plates.
- Discover® proprietary Vision Max® Paste Formula.
- Anchored plate groups to guard against vibration.
- Double insulating Micro porous glass fiber separators.
- Measured and Immobilized electrolyte.
- Vacuum filling and weighing processes.
- Advanced technology for efficient gas recombination of up to 99.9% and freedom from electrolyte maintenance.
- Wide range of operating temperatures (-40°C to 60°C).
- Low self discharge rates (Approx. 1%-3% monthly at 20 °C-25°C / 68°F-77°F).
- High impact reinforced strength copolymer ABS cases and flat top designed covers that are rugged and vibration resistant.
- Epoxy adhesion case to cover bonds that eliminate leakage.
- Copper and stainless steel alloy terminals and hardware.
- Multi-terminal options.
- Terminal protectors.
- Removable carry handles.
- Industry leading size and performance options.
- Classified as “NON-SPILLABLE BATTERY” Not restricted for Air (IATA/ICAO) Provision 67, Surface (DOT-CFR-HMR49) or Water (Classified as non-hazardous per IMDG amendment 27) transportation.
- Can be used in multiple orientations (upside down is not recommended).
- Compatible with sensitive electronic equipment.
- Quality Assurance processes with ISO (4400/992579), QS and TUV Certification EMC tested, CE, ETTS Germany (G4M19906-9202-E-16). UL recognized and approved components (MH29050).
- Tellcordia and Bellcore compliant.



Complies with DOT provisions listed in 49CFR173.159 (d). Special provision A67

Mechanical Characteristics

Industry Type No.	Volts	Standard (optional) Terminals	Dimensions in Inches (mm)				Approx. Weight in Lbs (Kgs)
			L in(mm)	W in(mm)	H in(mm)	TH in(mm)	

DIN	2	F10	8.3 (210)	6.8 (173)	13.0 (330)	14.4 (367)	61.7 (28)
-----	---	-----	-----------	-----------	------------	------------	-----------

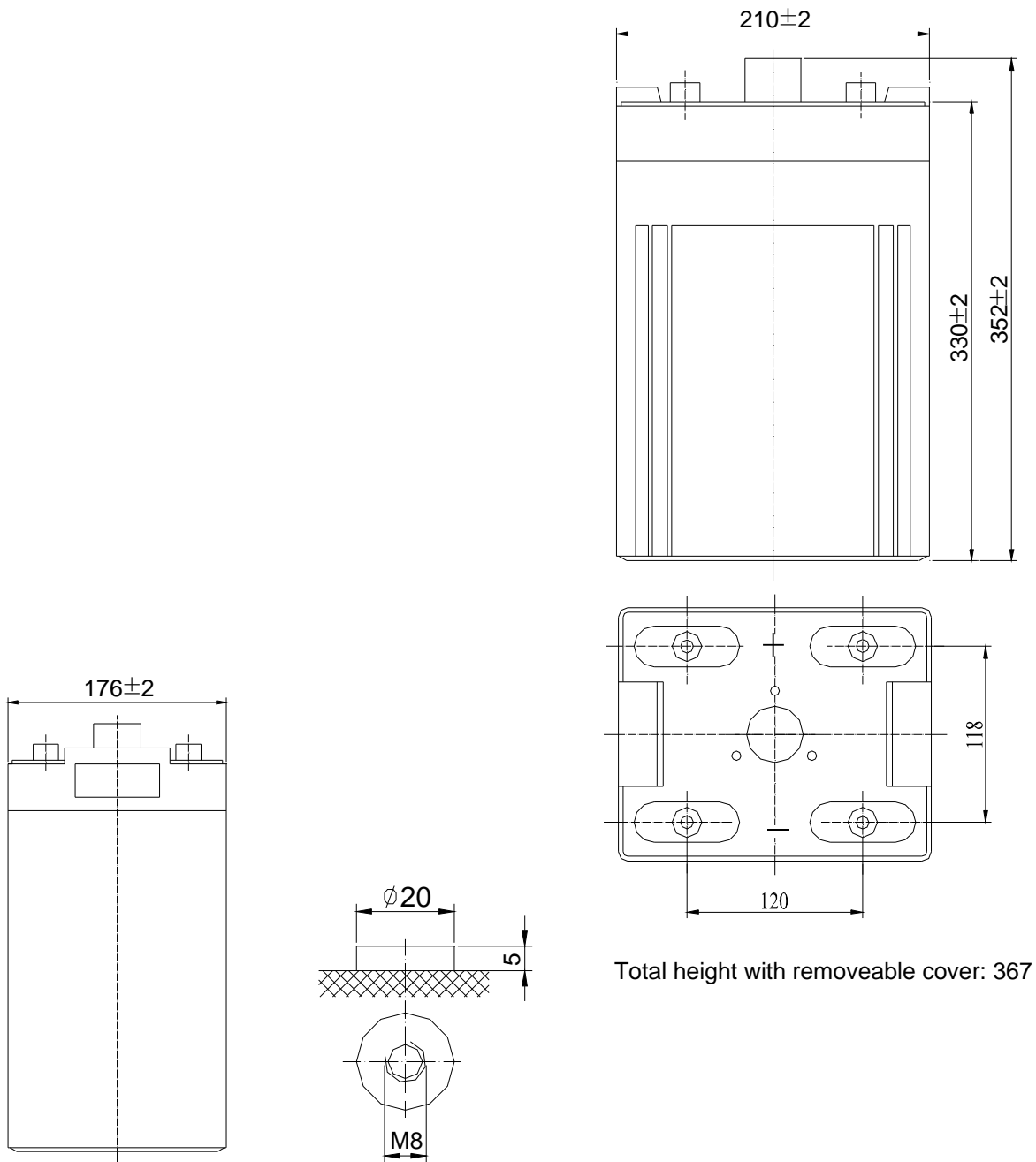

Electrical Specifications

Ampere Hour Capacity							
120HR	100HR	36HR	20HR	10HR	5HR	3HR	1HR
500	484	448	440	400	360	300	247
Minutes of Discharge					RC@25A	Cranking Amps	
@25A	@56A	@75A	@85A	@100A		32°F/ 0°C	0°F/ -18°C
1166	427	310	243	184	1060		

Constant current discharge ratings-amperes at 20°C (68°F)

End Point Volts/Cell	10min	15min	30min	45min	1h	3h	5h	10h
1.60V	732	587	427	325	247	114	77.7	43.0
1.65V	694	559	408	312	238	110	75.9	42.4
1.70V	654	530	388	298	229	106	74.0	41.7
1.75V	614	500	368	284	219	102	72.0	40.9
1.80V	573	470	347	269	208	98	69.4	40.0

Constant power discharge ratings-watts per cell at 20°C (68°F)

End Point Volts/Cell	10min	15min	30min	45min	1h	2h	3h	5h
1.60V	1281	909	740	641	493	310	214	140
1.65V	1206	860	703	610	471	286	209	138
1.70V	1131	810	665	576	449	270	203	135
1.75V	1057	760	626	543	425	260	197	132
1.80V	983	710	587	509	401	246	185	125

Internal resistance	Fully charged at 20°C: 0.47mOhms		
Self discharge	<3% of capacity per month at 20°C		
Operating temperature range	Discharge	Charge	Storage
	-20~60°C	-10~50°C	-20~60°C
Short circuit current (20°C)	4400 A		

CHARGE METHODS: Constant voltage charge at 20°C (68°F)	Charge voltage	Temperature compensation	Maximum Current	Peak 5 seconds	Peak 10 seconds	Maximum continuous	Recommended maximum continuous
Standby use	2.27-2.30V	-3.3mV/°C	Maximum charge current	1C10A	0.75C10A	0.5C10A	0.3C10A
Cyclic use	2.40-2.45V	-5mV/°C	Maximum discharge current	2C10A	1.5C10A	1C10A	0.5C10A

Contact Discover Engineering for OEM specific charging algorithms!

Charge / Discharge Tables & Graphs

