

Absorbed Glass Mat VRLA Industrial Battery Block

Discover® Clean & Green™ Series EV Traction Dry Cell Industrial Batteries provide superior high integrity and reliability for environmentally sensitive areas, commercial, industrial and private applications. The maintenance-free, valve regulated lead acid (VRLA) construction makes Discover® EV Traction Batteries the definitive choice for Mobility and Home Medical Equipment (HME); Broadband and Cable TV (CATV); Uninterruptible Power Supplies (UPS); Telecommunication; Photovoltaic, Solar and Renewable Energy Storage; Electronic and Security; Marine and RV; Golf and Electric Vehicle; Aerial Lifts and Fork Lifts; Floor Machines and Robotics.

Features & Benefits

EV Traction Dry Cell

- Completely sealed valve regulated construction.
- Flame arresting pressure regulated safety sealing valves for safety, operating pressure management and protection against atmospheric contamination (excess oxygen being absorbed by negative plates).
- Computer-aided 99.994% pure heavy-duty lead calcium grid designs.
- Tank formed plates guarantees evenly formed and capacity matched plates.
- Discover® proprietary Vision Max® Paste Formula.
- Anchored plate groups to guard against vibration.
- Double insulating Micro porous glass fiber separators.
- Measured and Immobilized electrolyte.
- Vacuum filling and weighing processes.
- Advanced technology for efficient gas recombination of up to 99.9% and freedom from electrolyte maintenance.
- Wide range of operating temperatures (-40°C to 60°C).
- Low self discharge rates (Approx. 1%-3% monthly at 20 °C-25°C / 68°F-77°F).
- High impact reinforced strength copolymer ABS cases and flat top designed covers that are rugged and vibration resistant.
- Epoxy adhesion case to cover bonds that eliminate leakage.
- Copper and stainless steel alloy terminals and hardware.
- Multi-terminal options.
- Terminal protectors.
- Removable carry handles.
- Industry leading size and performance options.
- Classified as "NON-SPILLABLE BATTERY" Not restricted for Air (IATA/ICAO) Provision 67, Surface (DOT-CFR-HMR49) or Water (Classified as non-hazardous per IMDG amendment 27) transportation.
- Can be used in multiple orientations (upside down is not recommended).
- Compatible with sensitive electronic equipment.
- Quality Assurance processes with ISO (4400/992579), QS and TUV Certification EMC tested, CE, ETTS Germany (G4M19906-9202-E-16). UL recognized and approved components (MH29050).
- Tellcordia and Bellcore compliant.



Complies with DOT provisions listed in 49CFR173.159 (d). Special provision A67

Mechanical Characteristics

Industry Type No.	Volts	Standard (optional) Terminals	Dimensions in Inches (mm)				Approx. Weight in Lbs (Kgs)
			L in(mm)	W in(mm)	H in(mm)	TH in(mm)	

DIN	2	F10	11.9 (302)	6.9 (175)	13.0 (330)	14.4 (367)	92.6 (42)
-----	---	-----	------------	-----------	------------	------------	-----------

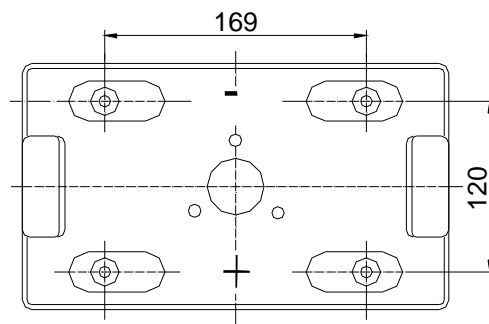
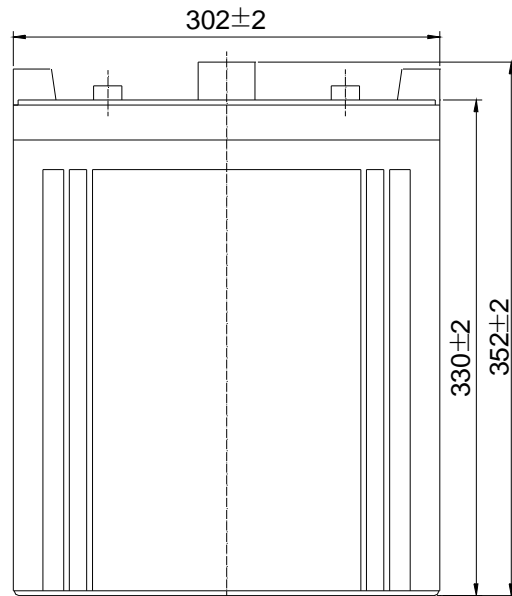

Total height with removeable cover: 367

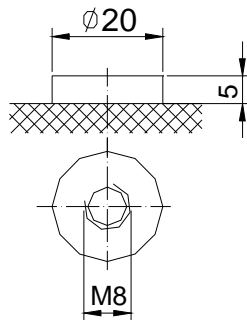
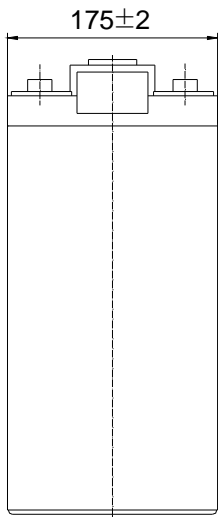

Electrical Specifications

Ampere Hour Capacity							
120HR	100HR	36HR	20HR	10HR	5HR	3HR	1HR
750	726	672	660	600	540	450	364
Minutes of Discharge					RC@25A	Cranking Amps	
@25A	@56A	@75A	@85A	@100A		32°F/ 0°C	0°F/ -18°C
1895	694	504	394	300	1720		

Constant current discharge ratings-amperes at 20°C (68°F)

End Point Volts/Cell	10min	15min	30min	45min	1h	3h	5h	10h
1.60V	1161	887	618	480	364	170	115	65.0
1.65V	1101	844	590	461	351	162	113	64.0
1.70V	1038	800	562	440	337	157	111	63.0
1.75V	974	755	533	419	322	150	108	61.0
1.80V	909	710	503	397	307	143	105	60.0

Constant power discharge ratings-watts per cell at 20°C (68°F)

End Point Volts/Cell	10min	15min	30min	45min	1h	2h	3h	5h
1.60V	1911	1424	1123	905	710	452	345	225
1.65V	1800	1347	1067	864	680	431	335	222
1.70V	1688	1269	1009	820	649	421	323	218
1.75V	1577	1191	951	776	617	400	312	214
1.80V	1467	1112	892	731	583	374	301	211

Internal resistance	Fully charged at 20°C: 0.30 mOhms		
Self discharge	<3% of capacity per month at 20°C		
Operating temperature range	Discharge	Charge	Storage
	-20~60°C	-10~50°C	-20~60°C
Short circuit current (20°C)	7000A		

CHARGE METHODS: Constant voltage charge at 20°C (68°F)	Charge voltage	Temperature compensation	Maximum Current	Peak 5 seconds	Peak 10 seconds	Maximum continuous	Recommended maximum continuous
Standby use	2.27-2.30V	-3.3mV/°C	Maximum charge current	1C10A	0.75C10A	0.5C10A	0.3C10A
Cyclic use	2.40-2.45V	-5mV/°C	Maximum discharge current	2C10A	1.5C10A	1C10A	0.5C10A

Contact Discover Engineering for OEM specific charging algorithms!

Charge / Discharge Tables & Graphs

