

## Absorbed Glass Mat VRLA Industrial Battery Block

Discover® Clean & Green™ Series EV Traction Dry Cell Industrial Batteries provide superior high integrity and reliability for environmentally sensitive areas, commercial, industrial and private applications. The maintenance-free, valve regulated lead acid (VRLA) construction makes Discover® EV Traction Batteries the definitive choice for Mobility and Home Medical Equipment (HME); Broadband and Cable TV (CATV); Uninterruptible Power Supplies (UPS); Telecommunication; Photovoltaic, Solar and Renewable Energy Storage; Electronic and Security; Marine and RV; Golf and Electric Vehicle; Aerial Lifts and Fork Lifts; Floor Machines and Robotics.

### Features & Benefits

### EV Traction Dry Cell

- Completely sealed valve regulated construction.
- Flame arresting pressure regulated safety sealing valves for safety, operating pressure management and protection against atmospheric contamination (excess oxygen being absorbed by negative plates).
- Computer-aided 99.994% pure heavy-duty lead calcium grid designs.
- Tank formed plates guarantees evenly formed and capacity matched plates.
- Discover® proprietary Vision Max® Paste Formula.
- Anchored plate groups to guard against vibration.
- Double insulating Micro porous glass fiber separators.
- Measured and Immobilized electrolyte.
- Vacuum filling and weighing processes.
- Advanced technology for efficient gas recombination of up to 99.9% and freedom from electrolyte maintenance.
- Wide range of operating temperatures (-40°C to 60°C).
- Low self discharge rates (Approx. 1%-3% monthly at 20 °C-25°C / 68°F-77°F).
- High impact reinforced strength copolymer ABS cases and flat top designed covers that are rugged and vibration resistant.
- Epoxy adhesion case to cover bonds that eliminate leakage.
- Copper and stainless steel alloy terminals and hardware.
- Multi-terminal options.
- Terminal protectors.
- Removable carry handles.
- Industry leading size and performance options.
- Classified as “NON-SPILLABLE BATTERY” Not restricted for Air (IATA/ICAO) Provision 67, Surface (DOT-CFR-HMR49) or Water (Classified as non-hazardous per IMDG amendment 27) transportation.
- Can be used in multiple orientations (upside down is not recommended).
- Compatible with sensitive electronic equipment.
- Quality Assurance processes with ISO (4400/992579), QS and TUV Certification EMC tested, CE, ETTS Germany (G4M19906-9202-E-16). UL recognized and approved components (MH29050).
- Tellcordia and Bellcore compliant.



Complies with DOT provisions listed in 49CFR173.159 (d). Special provision A67

## Mechanical Characteristics

Industry Type No.	Volts	Standard (optional) Terminals	Dimensions in Inches (mm)				Approx. Weight in Lbs (Kgs)
			L in(mm)	W in(mm)	H in(mm)	TH in(mm)	

DIN	2	F10	16.1 (410)	6.9 (175)	13.0 (330)	14.4 (367)	125.7 (57)
-----	---	-----	------------	-----------	------------	------------	------------

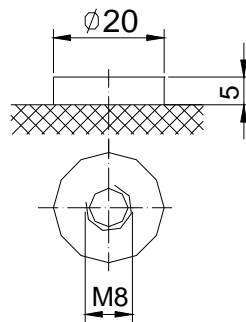
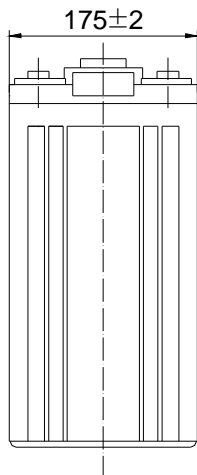
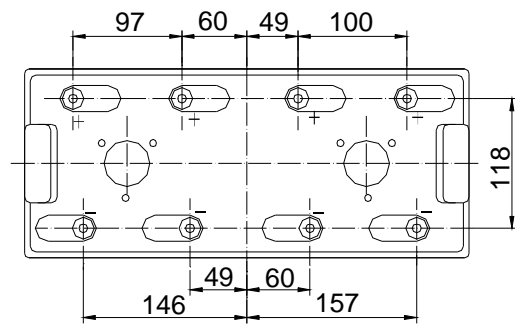
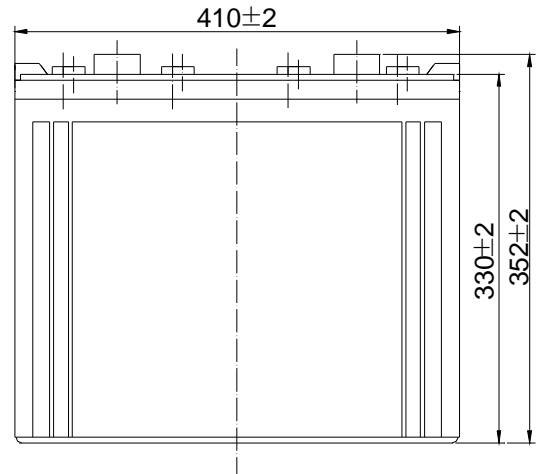

Total height with removeable cover: 367

## Electrical Specifications

Ampere Hour Capacity							
120HR	100HR	36HR	20HR	10HR	5HR	3HR	1HR
1000	968	896	880	800	720	600	496
Minutes of Discharge					RC@25A	Cranking Amps	
@25A	@56A	@75A	@85A	@100A		32°F / 0°C	0°F / -18°C
2254	934	679	531	428	2320		

Constant current discharge ratings-amperes at 20°C (68°F)

End Point Volts/Cell	10min	15min	30min	45min	1h	3h	5h	10h
1.60V	1576	1281	830	650	496	227	156	86.0
1.65V	1494	1219	793	624	478	220	152	84.9
1.70V	1409	1156	755	597	458	213	148	83.0
1.75V	1322	1091	716	568	439	204	144	81.8
1.80V	1233	1025	676	538	418	195	139	80.0

Constant power discharge ratings-watts per cell at 20°C (68°F)

End Point Volts/Cell	10min	15min	30min	45min	1h	2h	3h	5h
1.60V	2394	1995	1497	1133	936	632	451	303
1.65V	2255	1887	1422	1081	896	613	432	298
1.70V	2115	1777	1346	1027	855	594	413	292
1.75V	1975	1667	1267	971	812	575	394	286
1.80V	1837	1557	1189	915	769	556	375	271

Internal resistance	Fully charged at 20°C: 0.23 mOhms		
Self discharge	<3% of capacity per month at 20°C		
Operating temperature range	Discharge	Charge	Storage
	-20~60°C	-10~50°C	-20~60°C
Short circuit current (20°C)	9100A		

CHARGE METHODS: Constant voltage charge at 20°C (68°F)	Charge voltage	Temperature compensation	Maximum Current	Peak 5 seconds	Peak 10 seconds	Maximum continuous	Recommended maximum continuous
Standby use	2.27-2.30V	-3.3mV/°C	Maximum charge current	1C10A	0.75C10A	0.5C10A	0.3C10A
Cyclic use	2.40-2.45V	-5mV/°C	Maximum discharge current	2C10A	1.5C10A	1C10A	0.5C10A

Contact Discover Engineering for OEM specific charging algorithms!

## Charge / Discharge Tables & Graphs

